



# **THIS IS A CARAVAN DERBY**

## **SO PLEASE NOTE**

# **IN FAIRNESS TO COMPETITORS DOING THE RIGHT THING TOW A CARAVAN!!!.**

## **CARAVAN DERBY SPECIFICATIONS**

### **TOW CAR**

- ❖ Radiator optional front or rear.
- ❖ Bar work is allowed but must conform to modified sedan specifications.
- ❖ Both front windows and whole windscreen to be filled in with mesh.
- ❖ Max. 50 x 50mm. Min. 3mm thickness.
- ❖ Bird wire to be fitted over mesh screen front and sides. Max. 15mm square.
- ❖ Minimum 3mm plate bolted in driver's foot well.
- ❖ **TONGUE TO BE WELDED TO TOWBAR.**

### **CAR TYPE**

- ❖ Cars must be mono construction and use only original manufacturer's equipment (O.E.M.) in its entirety.
- ❖ No extra weights, reinforcing or cutting of bodies.
- ❖ Bull bars to be removed.
- ❖ All glass to be removed (except dashboard).
- ❖ All interior linings, trim, interior and exterior handles and ornaments must be removed.
- ❖ Windscreen mesh to be securely fitted, mesh size to be 50mm X 50mm X 3mm mm. wire diameter to cover entire driver and passenger windows and full windscreen area.
- ❖ Left hand front door latch to be removed.
- ❖ All doors to be chained shut, chain to go twice around door pillars and be bolted using min. 10mm bolts.
- ❖ Boot to be chained shut using min. of 2 chains.
- ❖ Bonnet to be chained in 3 places, 2 at front and 1 in centre at rear.
- ❖ Roof number (tin) mm. 300mm X 300mm in contrasting colour.
- ❖ No undesirable or obscene writing on cars or caravans.
- ❖ Drivers door to be painted in contrasting colour.
- ❖ Drivers name to be printed clearly on the roof above the driver.

### **SEATS AND SEATBELTS**

- ❖ A seat incorporating a head rest must be used.
- ❖ Seat back to be fixed to horizontal brace in roll-cage.
- ❖ Road type regulation lap - sash seatbelt securely fixed is a minimum requirement.
- ❖ Belts to be in good condition.
- ❖ If full race harness is used it must be mounted to bar work.

## **FUEL SYSTEM**

- ❖ Jerry can or boat fuel tank permitted.
- ❖ Pick up and breather pipes to enter top of tank.
- ❖ No electric fuel pumps (unless O.E.M.).
- ❖ Fuel tank to be securely mounted to bar work in left hand back seat area.
- ❖ Fuel line to have flexible section close to tank.
- ❖ Original fuel tank to be removed or have holes large punched in it.
- ❖ A non-spill vent is to extend through floor well clear of exhaust pipe.
- ❖ A tap to be fitted in the line within reach of the driver and marked in a contrasting colour.

## **FUEL ON—OFF**

## **ELECTRICAL SYSTEM**

- ❖ Battery is to be securely mounted to the bar work in a compartment located in the cabin area.
- ❖ Battery to be in an enclosed compartment covered with rubber and secured within the compartment.
- ❖ Effective "Kill Switch" to be mounted (centre front) on roof with all wiring external and neatly tied to window mesh.

## **OTHER MECHANICAL REQUIREMENTS**

- ❖ Brakes, steering and wheels to be roadworthy.
- ❖ Diff assemblies not to be turned over.
- ❖ Mufflers must be securely fitted and be effective.

---

## **ROLL CAGE AND CONSTRUCTION REQUIREMENTS**

- ❖ All bar work min. 38 x 3.2 – max. 50 x 3.2 black pipe.
- ❖ Bar work to be in cabin area only.
- ❖ All plates and washers 100 x 100 x 3.2mm minimum thickness.
- ❖ All bolts 12mm.
- ❖ All plates to have minimum of ONE bolt and no more than TWO.
- ❖ Main roll bar to be one piece and mandrel bent only, not heat formed.
- ❖ No galvanized pipes permitted.
- ❖ Main roll bar hoop must be placed as close as possible behind driver's seat.
- ❖ Roll cage mounting points must be secured through the floor pan using 12mm bolts and 100 x100 x 3.2mm washers.
- ❖ All joints must be professionally welded.
- ❖ Main roll bar to have horizontal brace as close as possible to shoulder height.
- ❖ One rearward brace only from top centre of main hoop to a plate bolted at rear.
- ❖ Side intrusion bars on both sides to be bolted to wheel well and extended back to main hoop at half door height.
- ❖ Drivers side only to have 3mm steel plate (one piece) attached to door pillars and side intrusion bar using 12mm "U" bolts (no drilling of bar work) or angle iron brackets and bolts. Plate must extend from bottom of door to window opening.
- ❖ Driver side only to have a one piece 3mm steel plate in floor pan to protect driver.
- ❖ Padding to be placed on all bar work and protrusions.

<p><b>Maximum 50 x 3.2 black pipe</b>  <b>Minimum 38 x 3.2 black pipe</b></p>	<p><b>3 Bonnet Chains</b></p>	<p><b>Kill Switch</b></p>
---	-------------------------------	---------------------------

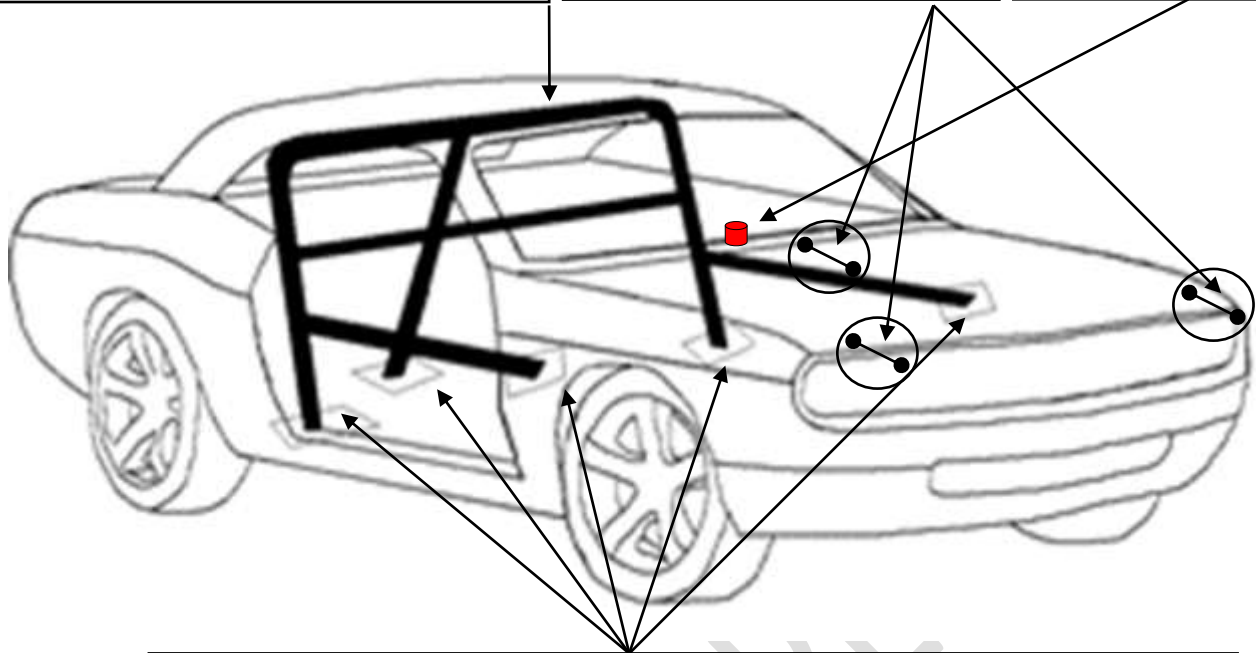

**100 x 100 x 3.2 mm Plates with same size washers bolted through floor.**  
**Minimum of TWO bolts in each plate.**

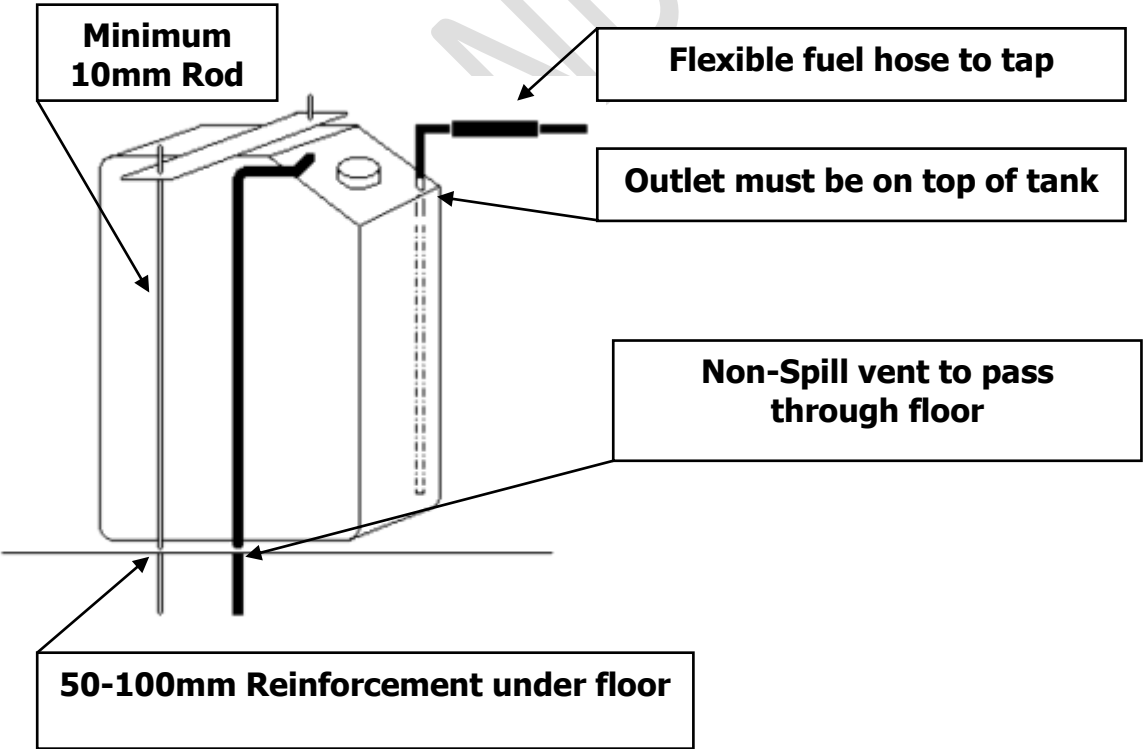

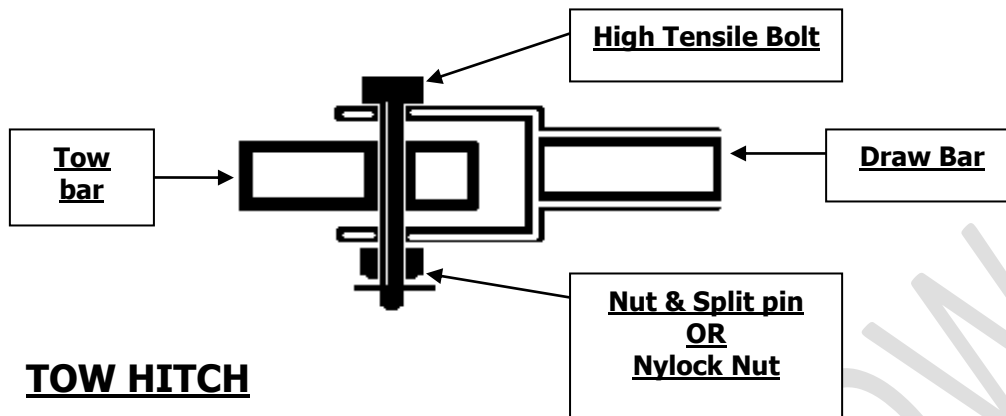

**SKID RAILS**

Skid Rails are to be fitted.

They are to be made of min. 25mm pipe or RHS.

- 1 On front to stop draw bar digging into the ground if it comes unhitched.
- 2 on chassis rails at rear with 100mm ground clearance.

